



Pumps and Systems

Commercial Duty Pumps

Heavy Duty Solids Handling Pumps

Grinder Pumps

Basin Package Assembly

Low Pressure Sewer Packages



Trusted. Tested. Tough.®



WHAT SETS ZOELLER PUMPS APART?

Since 1939, Zoeller Company has been manufacturing water pumps of many types. From pedestal pumps in the beginning to large HP, submersible, non-clog pumps in recent years, we have gained invaluable manufacturing experience from our humble beginning in August Zoeller's basement workshop.

Over the years, one of our most important mottos has been, 'We excel at 1,000 little things'. From start to finish, we take pride in our products. When you have residential or commercial wastewater issues, you can count on Zoeller to deliver the very best solutions. Our commitment to unsurpassed quality offers years of service and durability with a responsive and knowledgeable product support team just a phone call away.

- **MANUFACTURING IS IN OUR BLOOD...**

Rather than using a 'puzzle piece' mentality and simply buying components from other sources and assembling them, we manufacture most of our products from start to finish, continually checking the quality throughout the entire process.

Quality is always the most important element at Zoeller. Above all, quality is what has made us successful and continues to drive the decisions we make. A quality product cannot be manufactured with low-grade components. By bringing in high-quality raw castings as well as machining and powder coating the pieces in house, we are able to control the quality of each part and identify any defect throughout the manufacturing process. Each piece is subjected to numerous quality checkpoints along the way to guarantee that it is the best of the best.

- **FACTORY TESTING IS NOT JUST A BUZZWORD...**

Instead of running 'audits' on a calculated number of pumps, all submersible Zoeller pumps are 100% factory tested underwater prior to shipment. Each pump is subjected to a leak test to ensure that all gaskets, seals and mating surfaces will hold under pressure. After the pressurized leak test, the pump is powered up and run underwater to ensure that it is capable of the published head capacity and flow rate listed in our catalog and specification sheets. This testing allows us to guarantee the pump will operate out of the box every time, and you can rest assured that YOUR Zoeller pump was tested underwater for both electrical and hydraulic performance.

- **FULL BREADTH OF PRODUCT LINE...**

Zoeller is your 'one stop shop' when dealing with dewatering and wastewater systems. We offer everything from a small fractional sump pump to a large, 60 HP, non-clog pump. From battery back-ups, check valves, sewage grinder systems, small prepackaged residential units or large prepackaged municipal systems, Zoeller can offer it all. Next time you are looking for a water or wastewater system, reach for the only catalog you will ever need... Zoeller Company!

Professionals Training Professionals



The Center For Excellence training facility at Zoeller Company in Louisville, Kentucky offers a unique opportunity to experience the pump industry, learning from experts in the field. Bring your customers for an hour, a day, or more. Learn about the pump industry and why Zoeller products are designed to be the best for professionals.

What We Do

Gain first-hand experience in the unique and varied aspects of pump manufacturing and specification at our 6,000 ft² facility. In the demonstration room, our industry professionals offer live demonstrations and computer simulations of our latest products and core concepts. Lift stations including active controls are designed to demonstrate the how-and-why of pump technology. A state-of-the-art classroom provides space for lectures and group discussions with a library of cutaway models for reference.

Training Tailored To Meet Your Needs

Training experiences at the CFE are tailored to cover the specific topics that most interest you and your customers. All participants gain valuable technical and practical product knowledge. Our training staff will work with you to design the most profitable experience for your group. Some topics we have covered to date include:

Pump sizing

Troubleshooting a control panel

Product overview

Startup training

How performance curves are created

Rail systems



Email us! cfetraining@zoeller.com



Commercial Effluent & Sewage Ejectors

FEATURES:

- Submersible motor - Oil-filled, hermetically sealed, automatic reset thermal overload protected (1 Ph)
 - 6100 Series: 1/2 thru 2 HP, 60 HZ, 3450 RPM, 1 Ph or 3 Ph
 - 6280 Series: 1/2 or 1 HP, 60 Hz, 1750 RPM, 1 Ph or 3 Ph
 - 6290 Series: 1/2 thru 2 HP, 60 Hz, 3450 RPM, 1 Ph or 3 Ph
 - 6400 Series: 2 HP & 3 HP, 60 Hz, 1750 RPM, 1 Ph or 3 Ph
- Square rings and gasket - Viton
- Bearings - upper and lower ball
- Dual shaft seals - silicon carbide/carbon lower, carbon/ceramic upper
- Non-clogging vortex impeller design
- Durable cast iron cover, base, motor and pump housing
- 25' (8 m) UL listed, 3-wire neoprene cord and plug
- Stainless steel screws, bolts, handle, and shaft
 - 6100 Series: 1-1/2" NPT discharge with 2" or 3" bolt on flange option, 3/4" solids passing
 - 6200 Series: 2" or 3" NPT vertical bolt on flange, 2" solids passing
 - 6400 Series: 4" Horizontal ANSI flange discharge, 3" solids passing
- Corrosion-resistant, powder coated epoxy finish
- 100% computerized tested

AVAILABLE OPTIONS:

- Cord lengths of 35' (11 m) or 50' (15 m)
- Silicon carbide seal upgrade
- Moisture sensors for early warning of seal failure
- CSA Listed explosion proof models Class I, Division 1, Groups C & D and Class I, Zone 1, Groups IIA and IIB construction Tested to FM standards 3600 and 3615 by CSA
- Certified performance tests

ACCESSORIES:

- Rail systems and disconnects for standard installations
- UL Listed simplex and duplex control panels with NEMA 1 and 4X enclosures and float switches. Intrinsically safe relays for hazardous locations
- Fiberglass and HDPE basins, steel, aluminum and fiberglass covers
- Stainless steel and galvanized steel lifting cables
- HDPE basin and nylon rope also available
- Cast iron check valves

Products may not be exactly as pictured.

6100 Effluent Series



6200 & 6400 Sewage Series



Explosion Proof X6100-X6200-X6400 Series



* 200V/1Ph Models and Model 6186 are not UL Listed.

Pump Performance Curves



Explosion proof models share same performance curves.

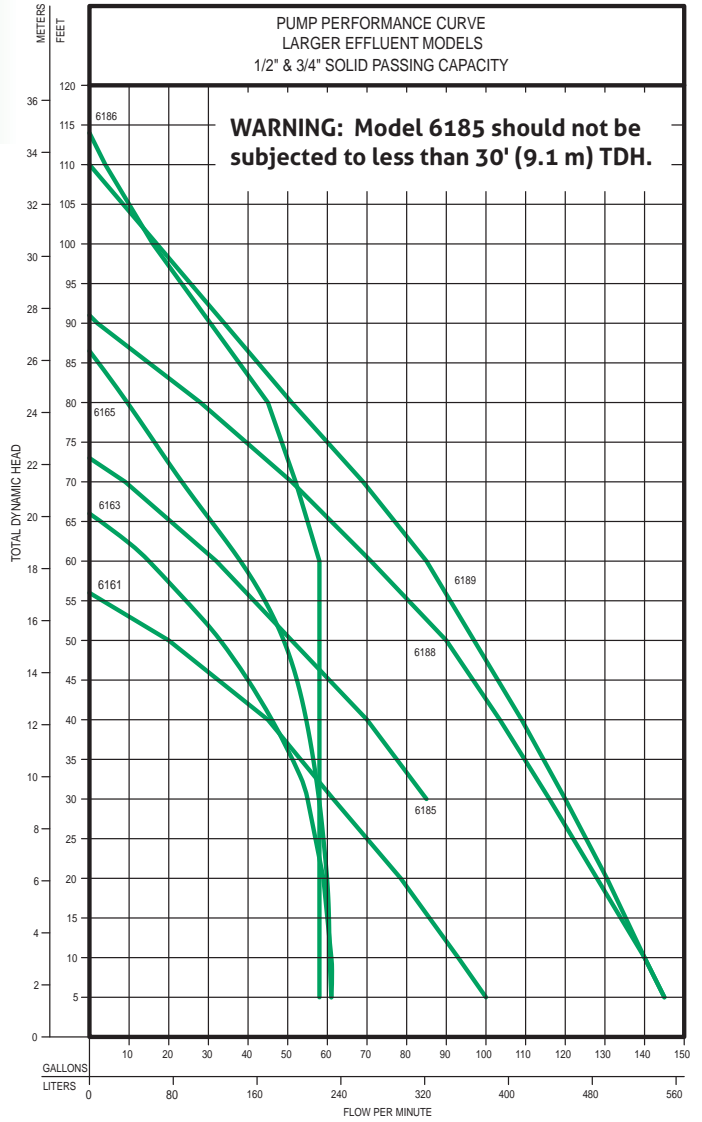

009922

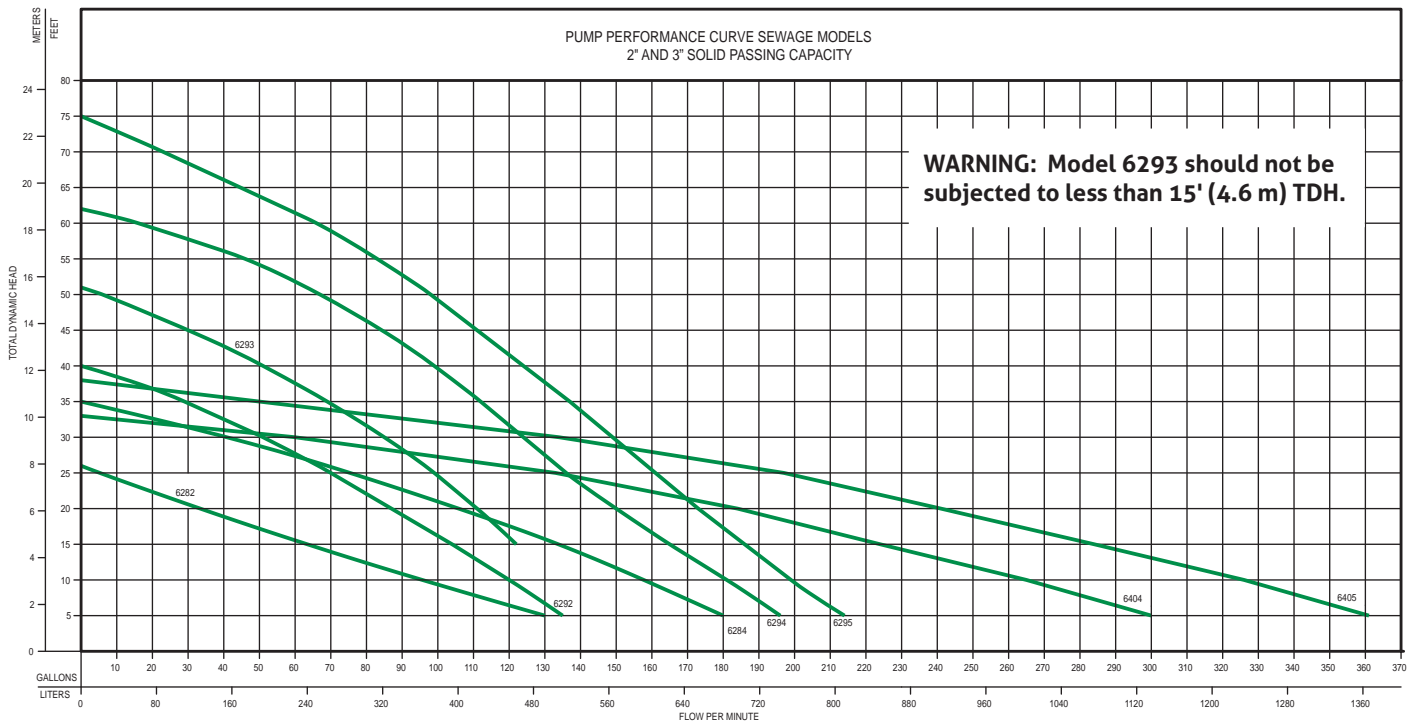

009904

Heavy Duty Solids Handling

FEATURES:

- Motor housing and volute - ASTM A-48 Class 30 cast iron
- Stainless steel hardware
- Corrosion-resistant, powder coated epoxy finish
- Ductile iron impeller
- Carbon/ceramic tandem mechanical seals protect the motor
- Balanced impeller and concentric pump housing
- Lifting lugs integral to the cast housing
- 61 HD, 62 HD & 64 HD Series with oil-filled motors. Moisture probes and temperature sensor with lead wires (optional on 61 HD Series). Single phase starting components are shipped loose or in optional enclosure
- X61 HD and X62 HD Series with CSA Listed explosion proof motors (Class I, Division 1, Groups C & D and Class I, Zone 1, Groups IIA and IIB Construction). Tested to FM standards 3600 and 3615 by CSA
- All models have a Class F insulation system with a maximum internal operating temperature of 294 °F (146 °C)
- Solids Handling Standard: (X)61HD – 2.5" solids, (X)62HD – 3.0" solids, (X)64HD 4" Discharge – 3 1/8" solids, 6" Discharge – 4.0" solids
- Two vane semi-open impellers with top pump-out vanes, enclosed impeller with top pump-out vanes, and vortex impellers with top pump-out vanes are available
- 25' (8 m) standard Type SOOW 4 conductor cords. Cord seal assembly engineered for water tightness

AVAILABLE OPTIONS:

- Vortex impeller (1 BHP thru 15 BHP)
- 3450 RPM motors (61 HD & X61 HD - 5, 7-1/2 & 10 BHP only)
- Additional cord lengths
- Trimmed impellers
- Silicon carbide seals
- Viton elastomers
- Bronze impellers
- Dry pit configuration (61 HD and 62 HD series only)
- High temperature design (61 HD and 62 HD series only)
- Inverter duty motor
- Certified performance tests

ACCESSORIES:

- Rail systems (cast iron/stainless steel) fitted for standard installations and non-sparking for Hazardous Locations
- UL Listed simplex and duplex control panels with NEMA 4X enclosures
- Intrinsically safe relays for explosion-proof series
- Fiberglass basins, steel or aluminum access covers with hatches
- Cast iron check valves
- Cast iron plug valves
- Dry pit base elbow
- Stainless steel and galvanized steel lifting cables
- Rail system adapters for using Zoeller pumps on competitors' rail systems



3" NPT Discharge
61 HD Series
1-10 BHP



Certified to CSA
Standard C22.2 No.108.
Tested to UL standard UL778



Flanged Discharge
61 HD & 62 HD Series
3", 1-10 BHP
4", 1-20 BHP
6", 5.0-20 BHP



Certified to CSA
Standard C22.2 No.108.
Tested to UL standard UL778



Flanged Discharge
64 HD Series
4" & 6", 25-60 BHP



Certified to CSA
Standard C22.2 No. 108



Pump Performance Curves

Standard Oil-Filled Motors 1-20 BHP

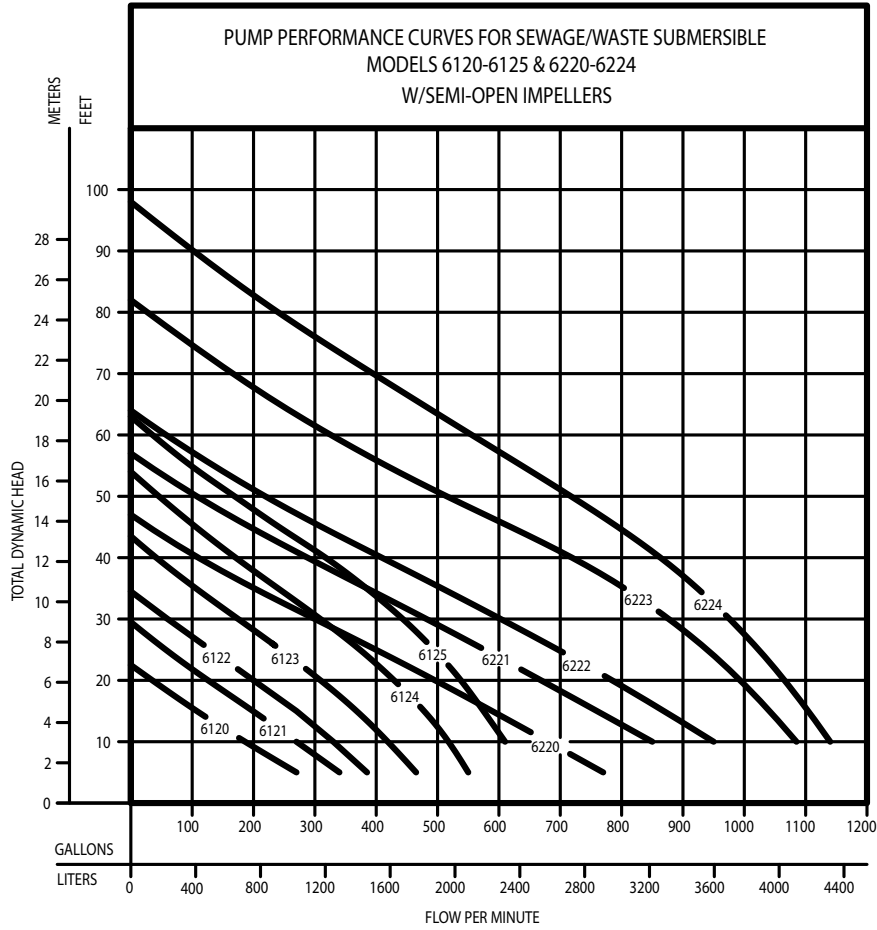

013937

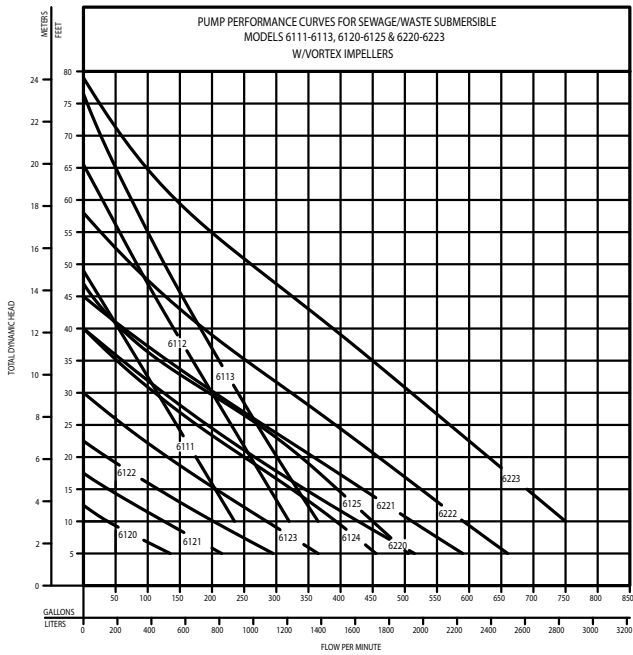

013936

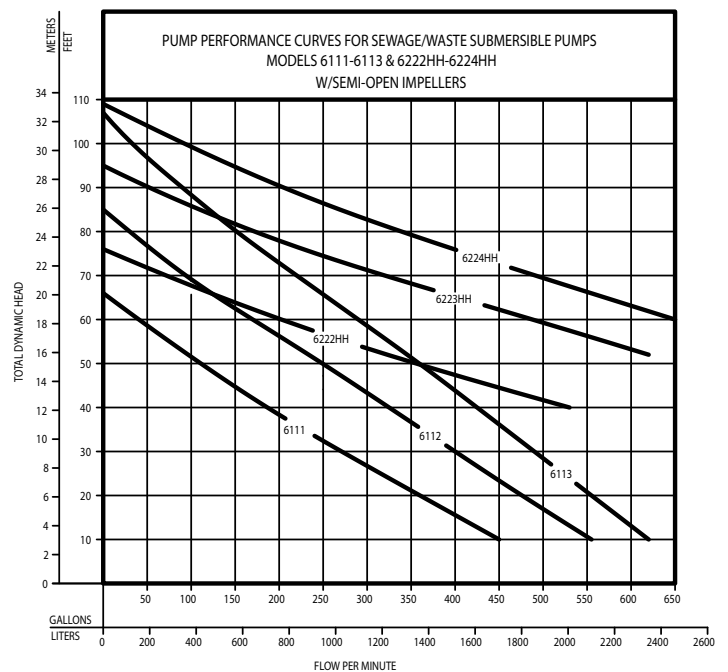

014486

Pump Performance Curves

Standard Oil-Filled Motors 25-60 BHP

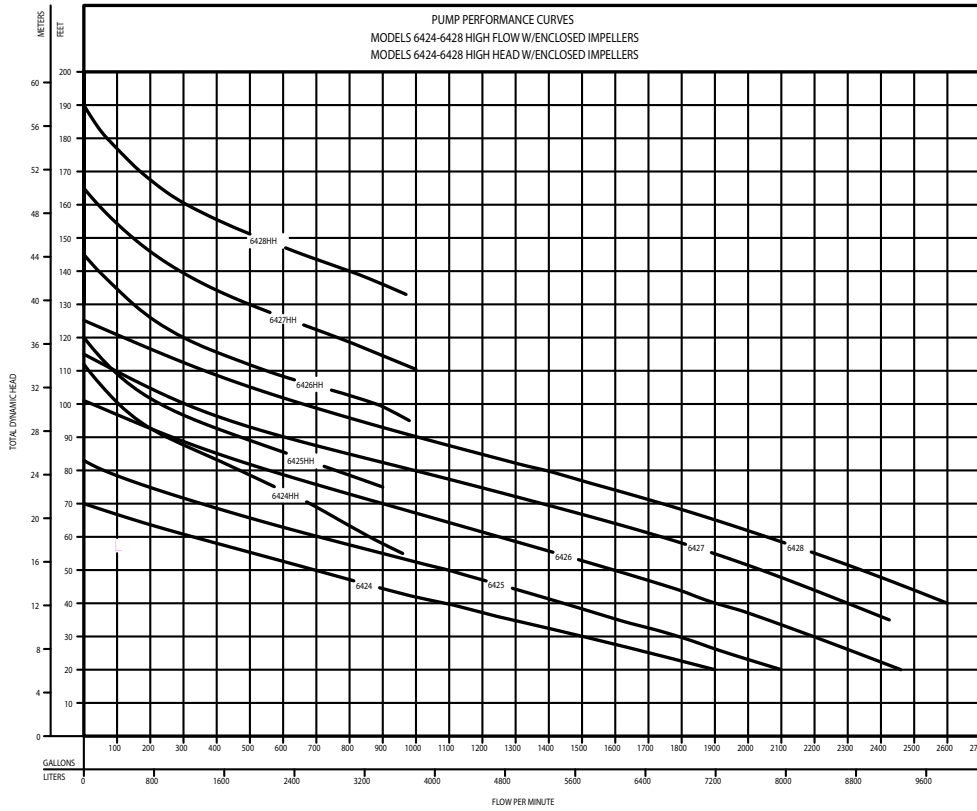

012996

Air-Filled, Explosion Proof Motors 25-60 BHP

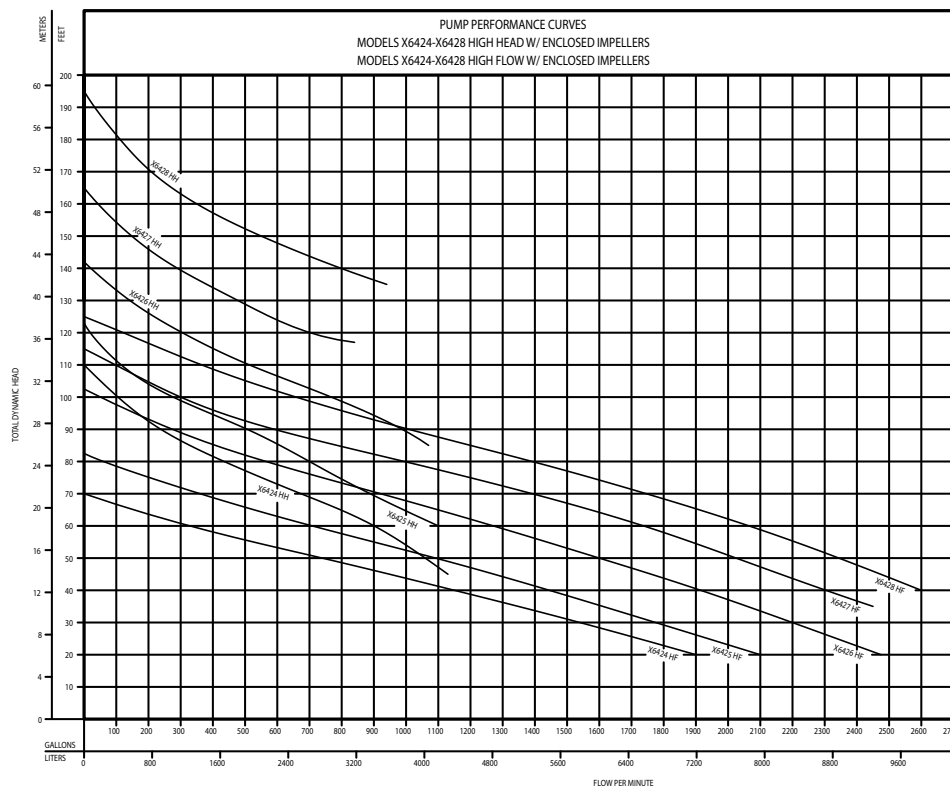

156936

70 Series Grinder Pumps

Models 7008, 7009, 7010 1, 1.5, 2 HP Grinder Pumps

STANDARD FEATURES:

- 1-1/4" NPT vertical discharge
- Silicon carbide/carbon mechanical seal
- Thermal overload protection (1 Ph)
- Engineered plastic, glass-filled impeller
- Stainless steel cutter and plate hardened to Rockwell C 55-60
- Viton square rings and gasket
- 20' (6 m) power cord
- Submersible motor, 60 Hz, 3450 RPM
- Corrosion-resistant, powder coated epoxy finish

OPTIONS:

- Silicon carbide/silicon carbide mechanical seal
- Additional cord lengths
- Automatic model with integral control
- Bronze impeller
- Trimmed impeller (7010 bronze impeller only)

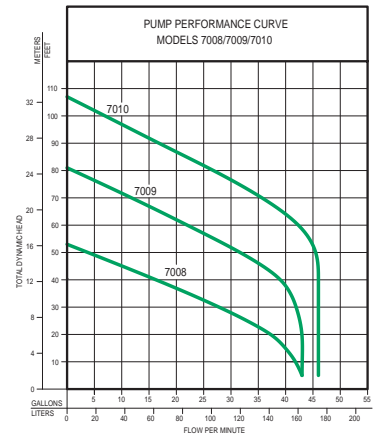

154108

Model 7011 - 2 HP Bidirectional Dual Seal Grinder Pump Model 7012 - 2 HP Single Directional High Head Model 7013 - 2 HP Single Directional High Flow

STANDARD FEATURES:

- 1-1/4" NPT vertical discharge
- Tandem seals - Silicon carbide/carbon lower, carbon/ceramic upper
- Class F insulated motor
- Thermal sensors (O.L. on 1 Ph)
- Moisture probes
- Vortex impeller: ductile iron (7011 & 7013), bronze (7012)
- Stainless steel cutter and plate hardened to Rockwell C 55-60
- Viton square rings
- Corrosion-resistant, powder coated epoxy finish
- 20' (6 m) power and sensor cord
- Submersible motor, 3450 RPM

OPTIONS:

- Silicon carbide/silicon carbide seal(s)
- Additional cord lengths
- Bronze Impeller (7011 & 7013)
- Trimmed impeller
- CSA Listed explosion proof models Class I, Division 1, Groups C & D and Class I, Zone 1, Groups IIA and IIB construction Tested to FM standards 3600 and 3615 by CSA.

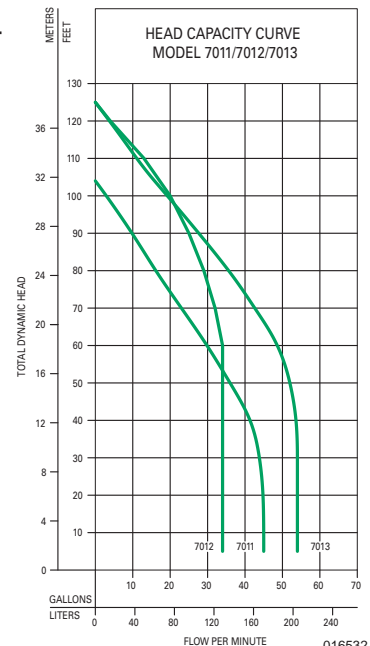

016532

Models 7020 & 7021 1 & 2 HP - Progressing Cavity STANDARD FEATURES:

ZEP LPS
Low Pressure Sewer Systems

- 1-1/4" NPT horizontal discharge
- Construction - Motor housing, cover, adapter and pump housing cast iron ASTM A-48, Class 30, 30,000# tensile strength, corrosion-resistant, powder coated epoxy finish
- Viton square rings and gasket
- Stainless steel cutter and plate hardened to Rockwell C 55-60
- Pressure relief valve
- Stainless steel mounting stand provides for free-standing installation
- Stainless steel helical hydraulic rotor
- Buna-N hydraulic stator
- 230 V / 1 Ph, 1750 RPM, 1 & 2 HP (200 V 2 HP optional)
- Housing - Finned cast iron, oil-filled

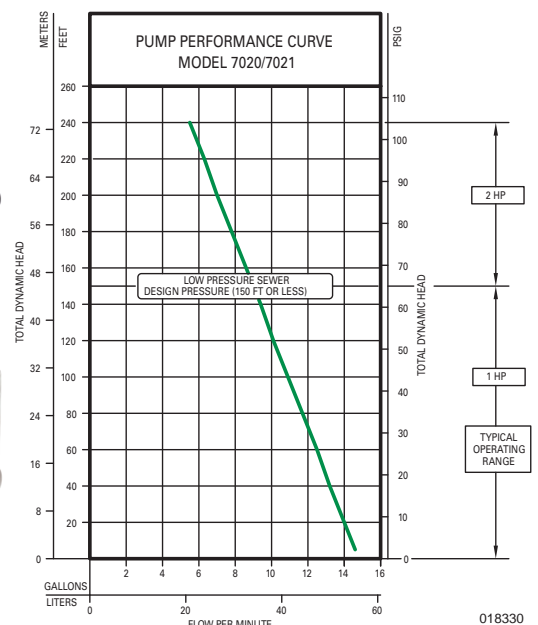

018330

3, 5 & 7-1/2 HP Grinder Pump Series

71 & X71 Series Grinder Pumps Models: 7110 (3 HP), 7111 (5 HP) & 7112 (7-1/2 HP) Models: X7110 (3 HP), X7111 (5 HP) & X7112 (7-1/2 HP)

STANDARD FEATURES: PUMP:

- 3 configurations - High Head - High Flow - Reversible
- 440 Stainless steel cutter & plate hardened to Rockwell C55-60
- Discharge size - 2-1/2" flanged horizontal adaptable to 3" flange
- Seals - dual mechanical carbon/rotary ceramic/stationary, Buna-N elastomers
- Seal leak probes and lead wires
- Construction - cast iron ASTM A-48, Class 30, 30,000# tensile strength, protected with a corrosion-resistant, baked-on epoxy powder coating
- Balanced impeller and concentric pump housing.
- Impeller - Ductile iron vortex design

MOTOR:

- 1 Phase - 230 Volts (3 & 5 HP High Head & High Flow models only)
- 3 Phase - 200/230/460/575 Volts, 3450 RPM
- Stator - Class F insulation and lead wires Nema B design
- Thermal sensor with leads
- Housing - Class 30 cast iron, oil-filled
- Ball bearings - Upper and lower high carbon chromium steel
- Power & sensor cable length - 25' (8 m)



OPTIONS:

- 2" NPT Vertical Discharge (HH & HF models only)
- Trimmed impeller
- Silicon carbide seals
- Viton Elastomers
- Bronze impeller
- Additional cord lengths
- CSA Listed explosion proof models Class I, Division 1, Groups C & D and Class I, Zone 1, Groups IIA and IIB construction Tested to FM standards 3600 and 3615 by CSA

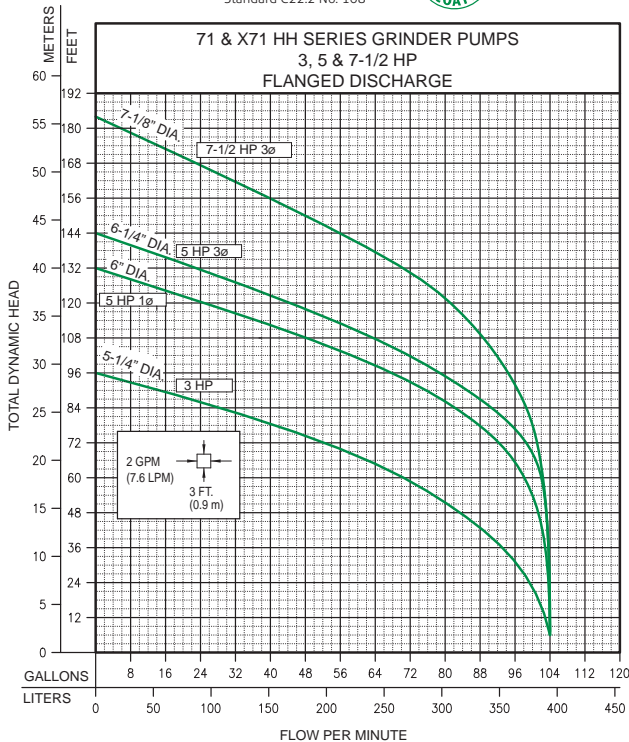
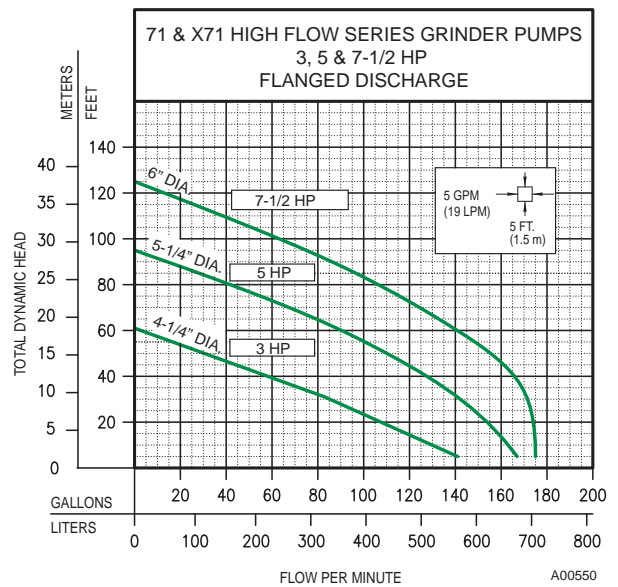

A00523

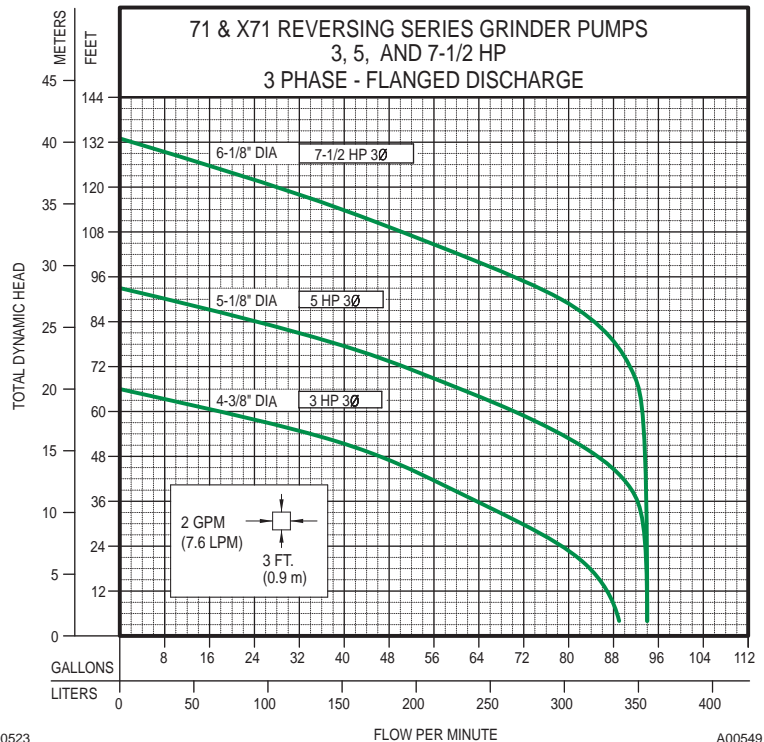

A00549

Basin Package Assemblies

INDOOR SIMPLEX AND DUPLEX BASIN ASSEMBLY

- Fiberglass basin up to 96" with anti-flotation ring
- Disconnect rail system with galvanized or stainless-steel rail guide pipes
- 1.25", 2", 3" or 4" Discharge through cover
- Sch 80, stainless steel or galvanized discharge piping
- Stainless steel lifting cable
- Ball valve(s) and check valve (s) *
- 1 - 4" Pipe seal, field installed
- Float bracket - (S-hook shown)
- Gas-tight steel or aluminum hatch cover

* valves will ship loose for field install

** consult factory rep for the right basin design for your application

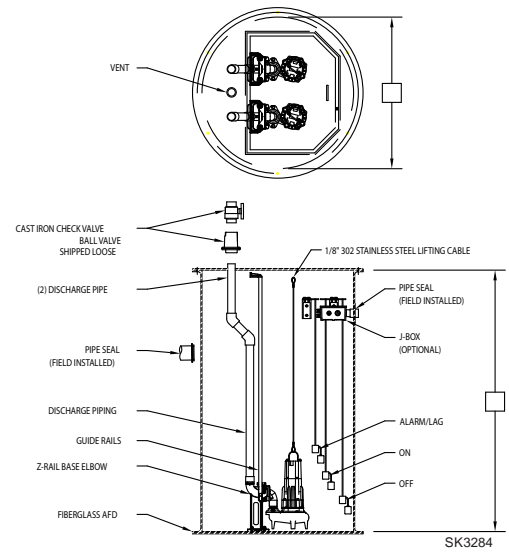

OUTDOOR SIMPLEX AND DUPLEX BASIN ASSEMBLIES

- Fiberglass basin up to 96" with anti-flotation ring
- Disconnect rail system with galvanized or stainless-steel rail guide pipes
- 1.25", 2", 3", 4" or 6" side discharge
- Sch 80, stainless steel or galvanized discharge piping
- Stainless steel lifting cable
- Ball valve(s)/plug valve(s) and check valve (s) installed
- 1 - 4" Pipe seal, field installed
- Float bracket - (float tree shown)
- Solid steel or fiberglass, gas-tight hatch or standard hatch steel or aluminum cover

*Consult factory rep for the right basin design for your application

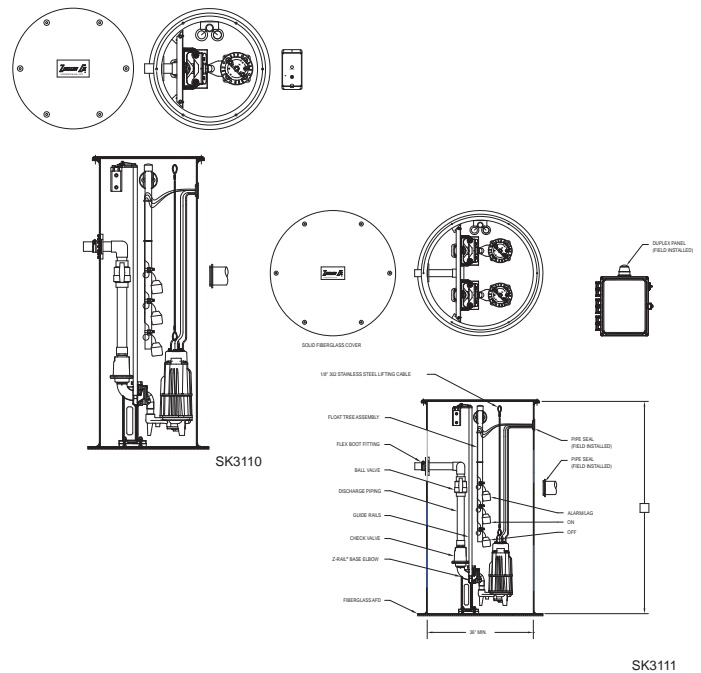

FIBERGLASS ASSEMBLIES WITH VALVE BOX OPTIONS

- Fiberglass basin up to 96" with anti-flotation ring
- Disconnect rail system with galvanized or stainless-steel rail guide pipes
- 1.25", 2", 3", 4" or 6" side discharge
- Sch 80, stainless steel or galvanized discharge piping
- Stainless steel lifting cable
- 1 - 4" Pipe seal, field installed
- 6 hook float bracket
- Solid steel or fiberglass, gas-tight hatch or standard hatch steel or aluminum cover
- Valve Box Options - attached or detached
- Ball valve(s)/plug valve(s) and check valve (s) installed

* Consult factory rep for the right basin design for your application

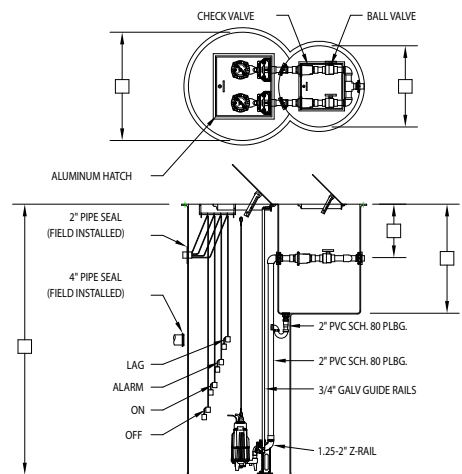

All system components are available individually.

Rotomolded Basin Packages

ZEP® LPS

Low Pressure Sewer Systems



Basin 31-2794 shown



24" riser 31-2952 shown



12" riser 31-2953 shown

Features:

- Constructed of high density polyethylene, formed from a roto-molding process, green or black available
- Integral ribs provide strength and prevent settling
- Anti-floatation flange, designed to be secured onto a pad, preventing flotation from high groundwater conditions
- Integral lifting lugs for ease of handling
- 3/8" thickness passing 3rd party vacuum and pressure testing procedures
- Basin surface contoured to direct the wastewater toward to pump's suction inlet
- Basin floor designed for either a Z-Rail® or free-standing pump installation
- Accessories built into basin design minimize bolts and fasteners
- Nesting extensions permits guide rail alignment
- Unlimited field inlet locations
- 12" and 24" risers available

Prepackaged System With Z Rail®:

- A practical and popular type package favored by many engineers and installers
- Corrosion protection with the use of SS and powder coated epoxy components
- Dual 3/4" 304 SS pipe rail system stabilizes and guides the pump while being raised or lowered into the basin
- System components securely installed, mounted directly to the basin wall for increased stability
- Float tree is utilized for ease of setting floats for operation and maintenance
- Schedule 80 PVC discharge piping, complete with SS shut-off, check, and anti-siphon valves
- Utilizes a flex-boot or bulk-head type discharge fitting, securing and stabilizing the discharge pipe when exiting the basin

Flex-Hose System:

- A cost savings alternative to the Z-Rail® type disconnect system
- Provides the same structural integrity as the Z-Rail but uses a steel reinforced rubber hose and disconnect fitting vs. pipe and rail system
- Thermoplastic disconnect with an O-ring provides a watertight seal up to 200 PSI
- Pump sits directly on the basin floor, supported by a SS pump mounting stand
- Schedule 80 ball valve and discharge piping from disconnect to discharge fitting
- SS check valve and anti-siphon valves
- Nylon lifting rope rated for up to 150 lbs.

Wet-Well/Dry-Well:

- A system designed specifically to meet customer expectations
- Provides the same structural integrity as the other basin packages manufactured by Zoeller® Company
- System provides automatic pump engagement and disengagement
- Wet well is isolated from the dry well, using a secondary cover mounted to an internal seal ring
- Flex hose systems or Z-Rail disconnect systems available.
- Includes check, shut-off, and anti-siphon valves
- Float tree is utilized for ease of setting floats for operation and maintenance
- Nylon lifting rope rated for up to 150 lbs.
- *Required with Z-Rail systems

4" PIPE SEAL
(SHIPPED LOOSE)

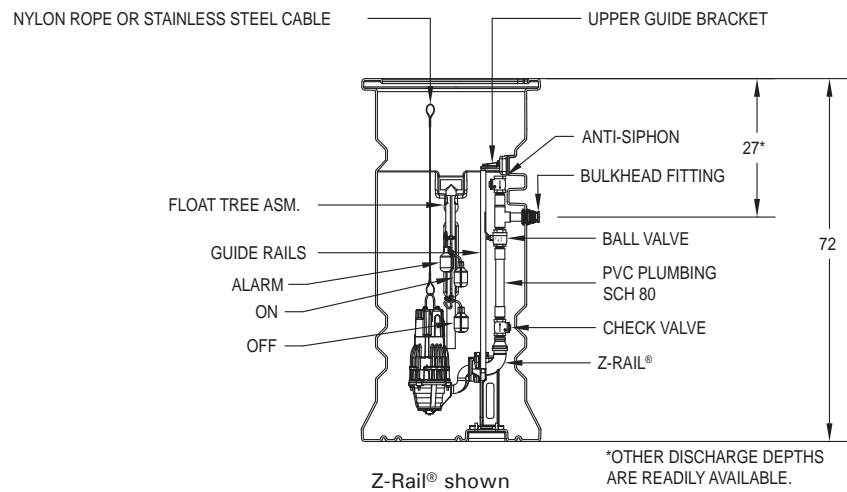
Z-Rail® shown

SOLID FIBERGLASS COVER

SYSTEM I.D. TAG.

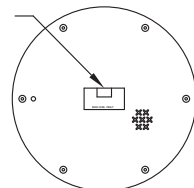

30X72 BASIN

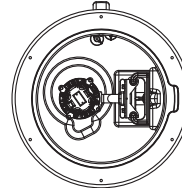

SIMPLEX PANEL
(FIELD INSTALLED)

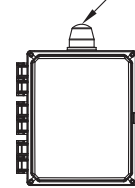

6932 Replacement Assembly For Progressing Cavity Grinders

ZEP® LPS Low Pressure Sewer Systems

FEATURES:

- Readily adapts to existing progressing cavity grinder pump systems
- Meets UL and NSF Pump Standards. Certified to NSF/ANSI 46 by CSA
- 1 HP, 230 volts, 60 Hz, 7.0 FLA
- 2 HP, 230 volts, 60 Hz, 10.5 FLA
- Electrical Quick-Disconnect (EQD) Plug
- Stainless steel hydraulic rotor with protective deflector plate
- Integral pressure relief valve
- Stainless steel fitted cover, stand, discharge, piping valves and fittings
- RWD7020 & 7021 systems with internally mounted level control
- Finned, Class 30 cast iron construction
- Corrosion-resistant, powder coated epoxy finish
- Discharge size - 1-1/4" NPT
- Oil-filled motor with integral thermal overload protection
- Viton seals and SC/C mechanical shaft seal
- Hardened 440 C stainless steel cutter and disc, Rockwell C55-60
- Red Nylon lifting rope
- Anti-siphon device (optional)

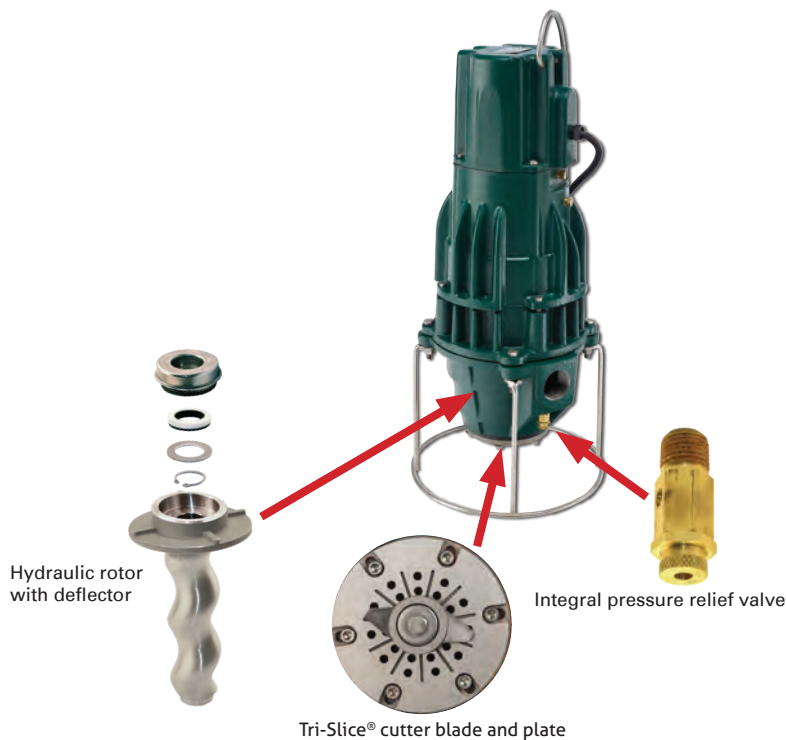

Lift Station Accessories

CONTROL PANEL STANDARD

Features:

- Simplex and Duplex configurations
- NEMA 4X outdoor rating
- Lockable hasp
- Pump disconnect
- Motor contactor
- 115 Volt control circuit
- Pilot lights and selection switches
- High water alarm circuits with dry contacts
- Seal leak indication
- Thermal cut-out circuit
- Reversing circuits for 7011 and 71 Series Reversing Grinder pumps

STANDARD OPTIONS:

- Inner door
- Elapsed time meter(s)
- Event counter(s)
- Alarm flasher
- Lightning arrestor/surge suppressor
- Anti-condensation heater
- Intrinsically safe relays for Class I and Division 1 location
- Redundant off circuit

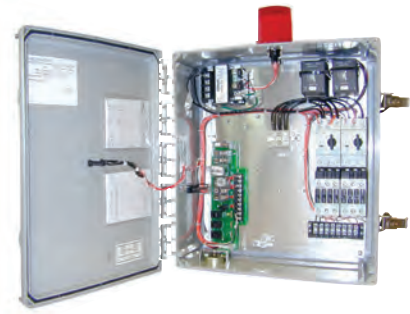

1-1/4" - 3" Threaded "Full-Flow" Unichecks

- Vertical or horizontal installation
- Full flow design - no restrictions
- Standard, 1-1/4", 1-1/2", 2", 3" female NPT pipe
- Neoprene polyester reinforced flapper - smooth edge design, with cast iron and noncorrosive metal backing plates and stainless steel fastener
- Rated at 50 psi (115' [35 m] of head) at 130 °F (54 °C)
- Cast iron body and stainless steel bolts
- Corrosion-resistant, powder coated epoxy finish



2" - 8" Flanged Check Valves for Sewage or Dewatering Applications

- Heavy duty cast iron construction
- Angled seal for non-slam closure
- Non-clog design
- Reinforced disc
- Drip tight seating
- Rated up to 200 psig
- Designed for both horizontal and vertical use



3", 4" & 6" FLYGT GUIDE RAIL SYSTEM ADAPTERS

Adapter plates for retrofitting 3", 4" & 6" horizontal discharge pumps to existing Flygt dual-pipe rail systems.

DESIGN FEATURES:

- Cast iron construction
- Flange conforms to ANSI B16.10 fully flat/MSS SP-6
- For use with all pumps with 3", 4" or 6" horizontal discharges and 2" NPT rail pipe
- Flange gasket and stainless steel bolts included

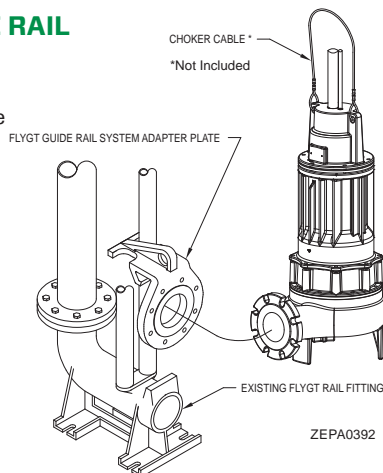

2" - 8" CAST IRON PLUG VALVES

Threaded Connection - 2" and 3"
Flanged Connection - 2"- 8"

FEATURES:

- Designed to handle solids-bearing flows
- Cast iron housing - rated 175 psi
- 99% pure nickel welded seat
- 1/4 turn Buna plug
- Upper and lower ball bearings
- Provided with hand lever



4" X 6" FLANGED DRY PIT MOUNTING STAND WITH CLEAN OUT

DESIGN FEATURES:

- Class 30 epoxy coated cast iron construction
- 6" inlet / 4" outlet
- Flanges conform to ANSI B16.10 fully flat/MSS SP-6
- For use on Dry-Pit pumps with 4" discharge
- 3" clean out plug

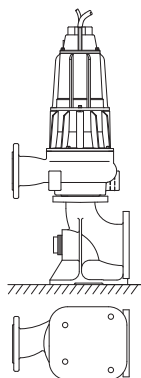

OIL DETECTION SYSTEM

DESIGN FEATURES:

- NEMA-4X alarm panel enclosure with test and silence switches
- Preset "on" and "off" points differentiate oil and water
- 20' (6 m) piggyback electrical supply cord
- 304 stainless steel probes
- UL508 approved switch



LPS System Accessories

Curb Valve Assembly #10-4698 1.25" #10-4893 2"



- Lateral valve assembly installed at the entrance of each pressure sewer site
- Includes a 316 SS curb stop valve and check valve
- Curb stop valve used to isolate site from pressure sewer
- Check valve provides redundant protection against potentially harmful backflows
- NPT connection for use with HDPE and PVC pressure sewer pipe and fittings (adapters included)
- Rated up to 200 PSI service pressure
- Designed for use with an optional curb box and valve extension rod

Curb Box with Valve Extension Rod #10-4875 (30" to 42" w/ 36" rod) #10-4867 (42" to 60" w/ 48" rod)



- Class 30 cast iron construction
- Conforms to ASTM A48 / A48M-03 specifications
- Designed to fit over and attach to a 1.25" curb stop valve
- Two sizes, selected by valve burial depths; adjustable 30" to 42" or 42" to 60"
- Depth adjustments, secured by internal threads
- Bolt down cover, imprinted with SEWER marking
- 5/8" OD steel rod with means for connecting to the curb stop valve
- Steel centering ring, for positioning and stabilizing the rod

Anti-Siphon Device # 10-4828

- Easily adapts to a 6932 replacement assembly
- Provides pump station air relief and anti-siphon protection
- 316 SS construction
- Rated up to 200 PSI



Round to Rectangular EQD Adapter Assembly #10-4824

- Enables a 6932 replacement assembly equipped with a round EQD to adapt to an existing rectangular EQD in the field
- Round female housing to a rectangular male housing
- 12" cord length, 14-6 SOOW jacketed neoprene cord
- "Tee" Nipples no included



Flexible Discharge Hose #10-4751

- 1.25" MNPT x 18" long
- Braided 304 SS flexible hose
- Rated up to 520 PSI
- Other lengths available



Red Lifting Rope #39-0162

- 3/8" x 12' braided polypropylene lifting rope
- For lifting pumps weighing up to 150 pounds
- Designed for strength, ease of handling and for mounting onto a pump's lifting bail



RWD-LPS Simplex Control, For Pumps Equipped with Integral Controls #61204-0001 & #61204-0002

- NEMA 4X enclosure, UL and CSA Listed
- Two types; standard design and one with a generator receptacle for a 20 amp NEMA L21-20P plug
- Manual run function and high water alarm
- Remote monitoring capability and ability to access historical performance data
- For complete details refer to sales document ZM3152



Guide Rail Systems

Z-RAIL® DISCONNECT SYSTEM FOR THREADED DISCHARGE PUMPS (1-1/4" - 1-1/2" - 2" - 3")

- Ductile iron construction, epoxy powder coated for corrosion protection
- Robust construction, designed to support a 300 lb. (136 kg) pump
- Tested to seat at heads up to 160 PSI (370' [113 m] TDH)
- Provides for an easy pump install or removal operation with no need for personnel to enter basin
- Compact design for easy installation
- Adaptable to most 1-1/4", 1-1/2", 2" and 3" pumps with a vertical NPT discharge
- 1-1/4" horizontal NPT discharge available for progressing cavity grinder pumps
- Grooved machined fit for a positive seated rail plate
- O-ring seals prevent leakage
- Uses 3/4" IPS guide rail
- Intermediate stabilizer for pits over 12' (3.7 m) deep

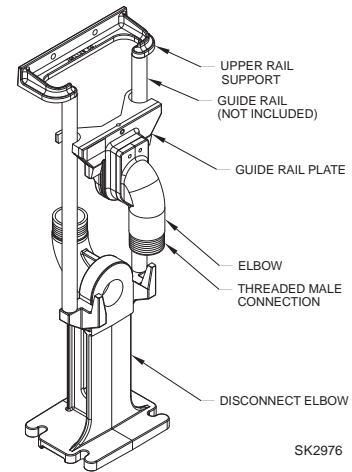

GUIDE RAIL SYSTEMS FOR FLANGED DISCHARGE PUMPS (4" & 6" DISCHARGE)

- Automatic engagement and easy disengagement
- Class 30 cast iron fittings (4" & 6" flanged) discharge
- Epoxy coated casting discharge
- Supports pump
- 2" IPS guide rails, stainless steel or galvanized steel pipes recommended (not furnished)
- Intermediate stabilizers for pits over 15' (4.6 m) deep
- Bronze fitted rail system available for non-sparking requirements for Class I, Division 1, Group C & D installations



4" & 6" Systems



2-1/2" & 3" Horizontal Flanged

Products may not be exactly as pictured

Notes

Notes



ABOUT THE ZOELLER FAMILY OF WATER SOLUTIONS

Founded in 1939, Zoeller Company is one of the oldest independently-owned professional pump manufacturers in North America. Headquartered in Louisville, Kentucky USA, Zoeller has over 800 employees worldwide and close to 600,000 sq. ft. of manufacturing facilities from our seven operations in North America and Asia.

Zoeller Company has established itself as an innovative leader in pumping equipment and water treatment systems by continuous research and development. The quality of our products is demonstrated by UL, CSA, CE, and NSF listings as well as continued growth throughout the United States, Canada, Mexico, and over 40 other countries around the globe. The company has also expanded to include five brands, which have become the foundation of Zoeller.



The original Zoeller product line now resides in Zoeller Pump Company, which offers a broad range of submersible pumps from fractional to 7-1/2 HP for residential and commercial sump, effluent, dewatering and grinding applications.



Flint & Walling, founded in 1866 in Kendallville, Indiana USA, is the only pump company in the U. S. to manufacture its own motor for jet and centrifugal pumps. This product line specializes in deep well pumps that range from 5 GPM to 1,000 GPM, as well as centrifugal, jet, booster, and submersible pumps up to 7-1/2 HP.



Founded in 1952, Wolf Pump is a manufacturer of submersible turbine pumps located in Abernathy, Texas. Wolf currently produces 4" to 8" pumps with capacities ranging from 35 to 1000 GPM. These pumps are known for their efficiency and durability in demanding water applications including irrigation, municipal water supplies, dewatering applications, dairy production, mining, the oil and gas industries, aquaculture, and more.



Zoeller Engineered Products provides products for storm water removal, sewage pumping stations and hazardous environment applications for residential, commercial and municipal markets. Available from 1/2 BHP to 60 BHP, each pump is customized by design, manufacture and installation according to exact application needs.



Clarus Environmental offers sustainable environmental products, solutions, and services for the collection, treatment, and dispersal of residential and community wastewater. This line specializes in onsite pumps, pressure sewers, biological and mechanical treatment processes, disinfection, and discharge of safe water.

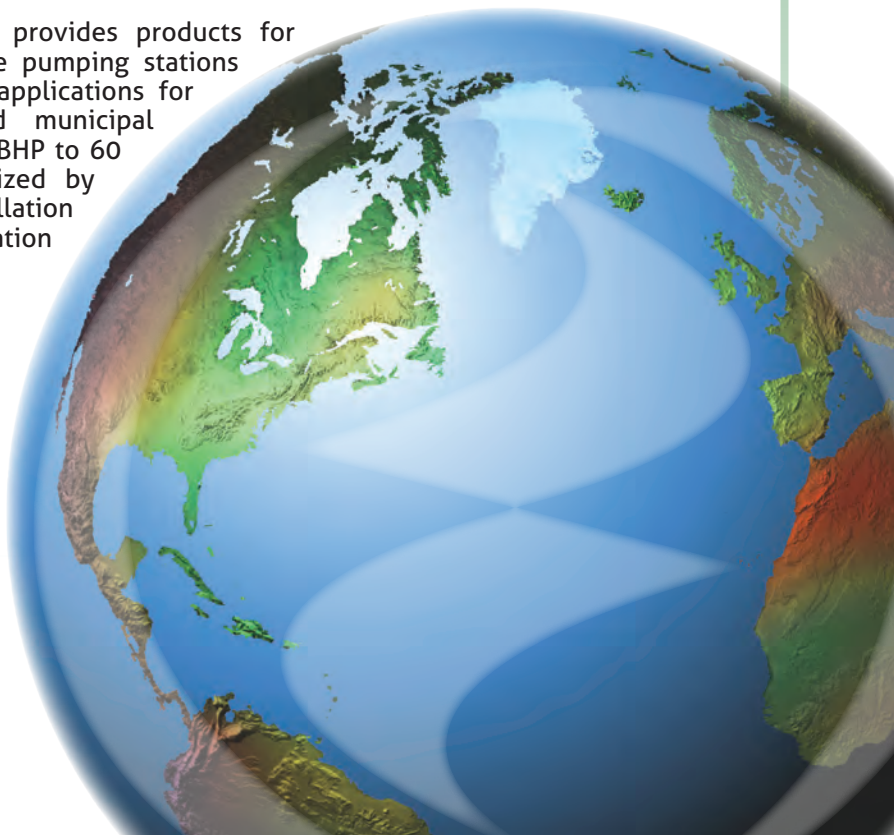

SECTION: Z0.00.050

ZM1191

0320

Supersedes

0519



3649 Cane Run Road • Louisville, KY 40211 • 502-778-2731 • 1-800-928-7867 • zoellerengineered.com